

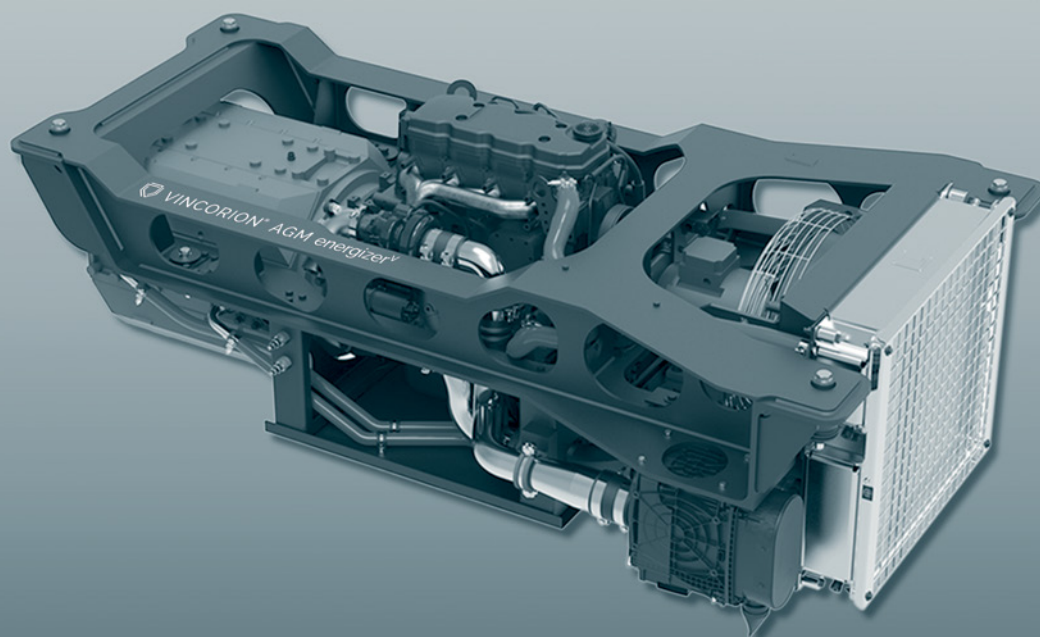

# VINCORION®



INDIVIDUAL SUPPORT. **LONG-TERM.**



## AUXILIARY ALTERNATORS AND GENSETS. KEEPING THE ON-BOARD POWER SUPPLY ON TRACK.

**From the alternator to the complete genset.  
VINCORION has it.**

For years, VINCORION has been designing and producing special alternators for on-board power supply for rolling-stock companies around the world. And powering for air-conditioning systems in trains in Turkey, Iran, Israel, or the Philippines is challenging. Since a breakdown has a direct impact on passengers, powerful and reliable auxiliary energy systems are essential. Our Auxiliary Alternators and Systems with modern engines, independent cooling, integrated controlling, etc. are highly sophisticated systems and tailor-made to your specifications.

They have customized designs to fit individual train layouts with low noise and exhaust emissions.

### THE EXTRA ENERGY BOOST

- On-board electrical system for passenger cars with additional electricity needed for lighting, air-conditioning, etc.
- Intelligent, demand-oriented control of multiple units
- Outdated APUs can be replaced using existing interfaces and without further technical adaptations to the train design

# FLEXIBLE ON-BOARD POWER SUPPLY. AUXILIARY ALTERNATORS AND GENSETS.

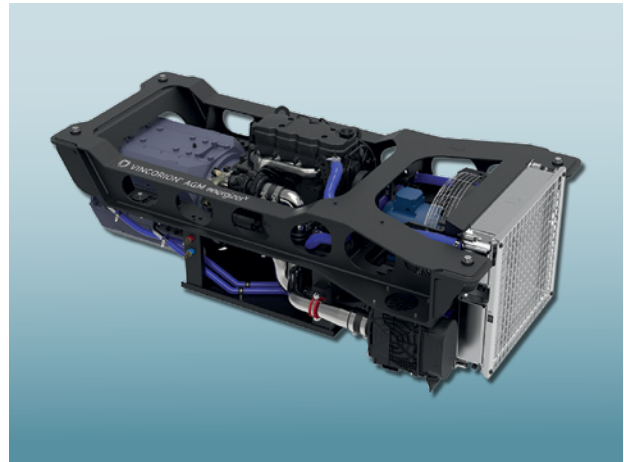

## AAM ENERGIZER<sup>V</sup>

These VINCORION alternators were especially developed for the on-board power supply of railway vehicles. Our wide range of alternators offers auxiliary energy solutions for all types of rolling stock, from main-line locomotives to single passenger cars. The impregnation of the alternator windings is performed with a modern current-UV-light dipping process, where monomer-free impregnating varnish is applied. Production and testing of the alternators are conducted according to EN 60349-1 and EN 60349-4. And VINCORION Auxiliary Alternators can be ordered according to customer-specific specifications – your wish is our command.

## AGM ENERGIZER<sup>V</sup>

These compact-design gensets were developed for the on-board power supply of railway vehicles and can be customized to different train layouts, including underfloor integration. The gensets are driven by high-tech diesel engines. They are actuated by an electric control device containing all necessary protection, operating, and control components, including the electronic regulating device. The control cabinet, cooling unit, and silencer are integrated into the genset according to the customer's requirements. The Gensets are designed according to UIC 566. Production and testing of the gensets are conducted according to EN 60349-1 and EN 60349-4 as well as EN 12663 and UIC 566.

### AAM energizer<sup>V</sup>

#### Technical Specifications\*

Rated Power	From 5 kW to 1,000 kW
Voltage	From 24 V DC to 3,000 V DC From 220 V AC to 1,500 V AC
Design	Synchronous, brushless Permanent magnet, brushless
Speed	Fixed speed 1,000 / 1,500 / 3,000 min <sup>-1</sup> Variable speed
Cooling Mode	Self-cooling Air-cooled (open-circuit ventilation) Air-cooled (surface cooling) Water-cooled

\*Construction variations and additional options possible upon request.

### AGM energizer<sup>V</sup>

#### Technical Specifications\*

Rated Power	From 25 kW to 1,000 kW
Voltage	From 24 V DC to 3,000 V DC From 220 V AC to 1,500 V AC
Design	Synchronous, brushless Permanent magnet, brushless
Speed	Fixed speed 1,000 / 1,500 / 3,000 min <sup>-1</sup> Variable speed
Cooling Mode	Air-cooled (open-circuit ventilation) Air-cooled (surface cooling) Water-cooled

\*Construction variations and additional options possible upon request.



VINCORION Power Systems GmbH  
Suedliche Roemerstrasse 12-18 | 86972 Altenstadt | Germany  
Phone +49 8861 710-110 | railway@vincorion.com  
www.vincorion.com