

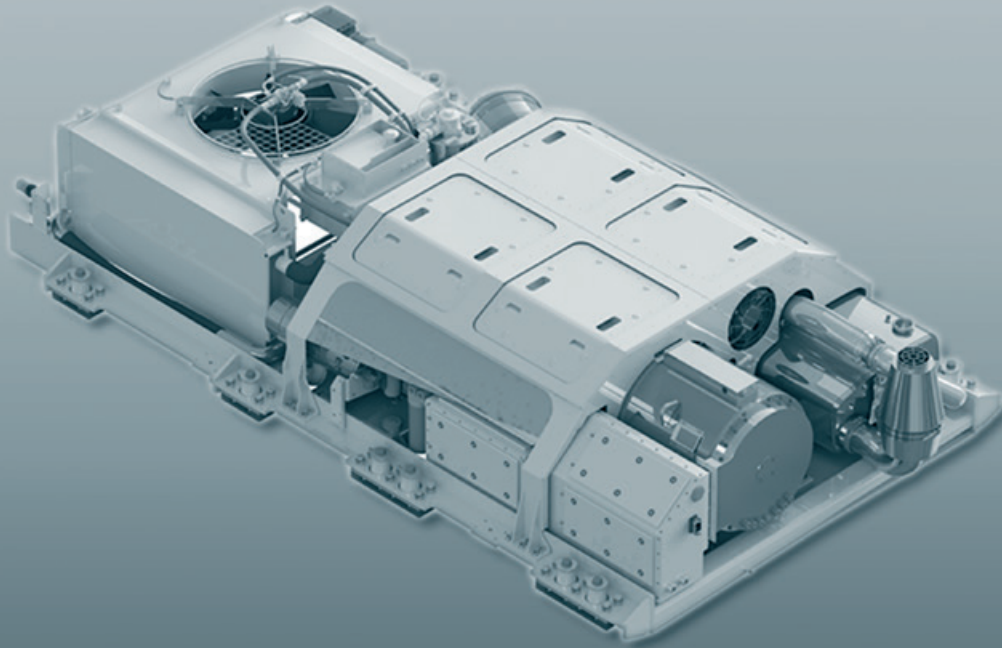

VINCORION



STABILITY. POWERFUL.

VINCORION TRACTION GENSETS AND ALTERNATORS. THE POWER TO MOVE TONS OF ROLLING STOCK.

VINCORION Traction Gensets and Traction Alternators are designed to provide your train layouts with high energy density.

Our Traction Gensets and Traction Alternators were designed with limited installation space in mind. So energy is provided compactly in a very small installation space, freeing up the remaining space for other uses. They are also weight-optimized with a flat design for roof mounting and customizable for underfloor mounting.

The VINCORION Traction Gensets and Traction Alternators use state-of-the-art technology for diesel engines and alternators to enable flexible train operation profiles. Moreover, they have been designed for clean operation, with low exhaust emissions, variable speeds, and hybrid energy operation. With VINCORION, you have one contact partner for the complete energy system, from alternators to motors, coolers, converters, controllers, and hybrid technology, thus reducing interfaces and facilitating support for the whole life cycle.

VINCORION POWER FOR RAILWAY TRACTION. MAKING THE MOST OUT OF LIMITED INSTALLATION SPACE.

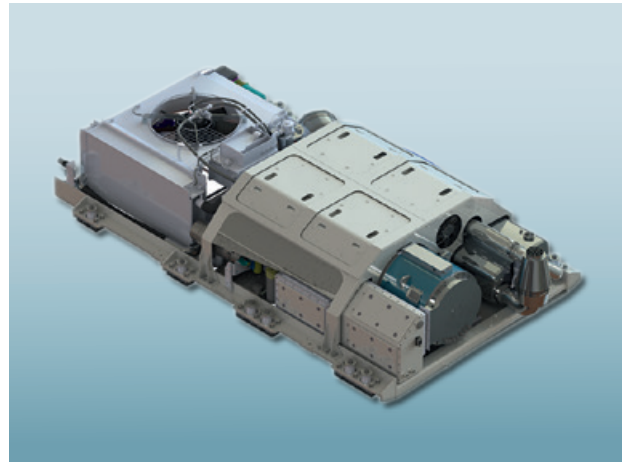
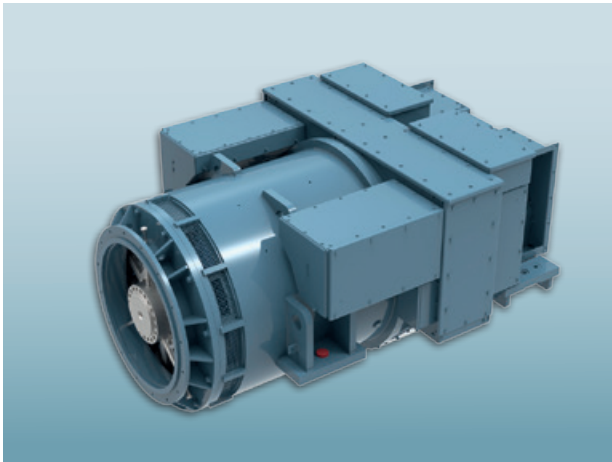

VINCORION TRACTION ALTERNATORS

These VINCORION alternators were developed for the power supply of railway vehicles' traction engines. We can supply this type of alternator for DMUs, and shunting or heavy mainline diesel locomotives either in a one-bearing or in a two-bearing version, customized to your requirements. The impregnation process of the alternator windings is performed with a modern current-UV-light dipping method where monomeric-free impregnating varnish is applied. The electronic and control device is manufactured and delivered as a separate unit. Production and testing of the alternators are conducted according to EN 60349-1 and EN 60349-4.

Traction Alternators: Superior Power Supply

Technical Specifications*

Rated Power	From 200 kW to 3,000 kW
Voltage	Max. 3,000 V DC Max. 2,000 V AC
Design	Synchronous, brushless Permanent magnet, brushless
Cooling Mode	Air-cooled (open-circuit ventilation) Air-cooled (surface cooling) Water-cooled
Options	Direct-mounted charging alternator Direct-mounted auxiliary alternator

*Construction variations and additional options possible upon request.

VINCORION TRACTION GENSETS

These VINCORION gensets were developed for the power supply of railway vehicles' traction engines. As system provider, we undertake the underfloor, roof, or internal mounting of the energy system. The gensets are driven by high-tech diesel engines. The gensets are actuated by an electronic control device, containing all necessary protection, operation, and control components. The control device, cooling unit, and silencer can either be integrated into the genset or supplied separately. Gensets are designed according to UIC 566. Production and testing of the gensets are conducted according to EN 60349-1 / EN 60349-4 and UIC 566 / EN 12663.

Traction Gensets: Dependable Power

Technical Specifications*

Rated Power	From 200 kW to 3,000 kW
Voltage	Max. 3,000 V DC Max. 2,000 V AC
Design	Synchronous, brushless Permanent magnet, brushless
Cooling Mode	Air-cooled (open-circuit ventilation) Air-cooled (surface cooling) Water-cooled
Options	Direct-mounted charging alternator Direct-mounted auxiliary alternator Auxiliary inverters

*Construction variations and additional options possible upon request.